

Beset



OR-TUB-BESET6032-X

SIZE:
60" x 32" x 18.5"

WATER CAPACITY:
70 Gallons

WEIGHT:
225-265 Pounds

BACK SLOPE:
28°

MATERIAL:
1-2" Nominal Thickness
solid surface material

FINISH:
Matte, Gloss

WARRANTY:
10 Year Warranty.

FEATURES:

- MicroMount available in Drop-In models.
- Integral waste and overflow included.
- Pre-wired pump on pump platform.
- Integral EZ level platform
- Overflow and drain comes standard in chrome, unless specified otherwise.
- Bathtub available in 16 different color choices

OPTIONAL:

- Thermal Air System
- Whirlpool Pump: 12"(H) x 16"(L)
- Thermal Air Blower Pump: 5"(H) x 11"(L)
- Hydro Fusion: 7"(H) x 15.5"(L)
- Hydro Indulge: 11"(H) x 19"(L)
- Electrical Requirements 1 15 AMP dedicated circuit, GFCI-115 Volts

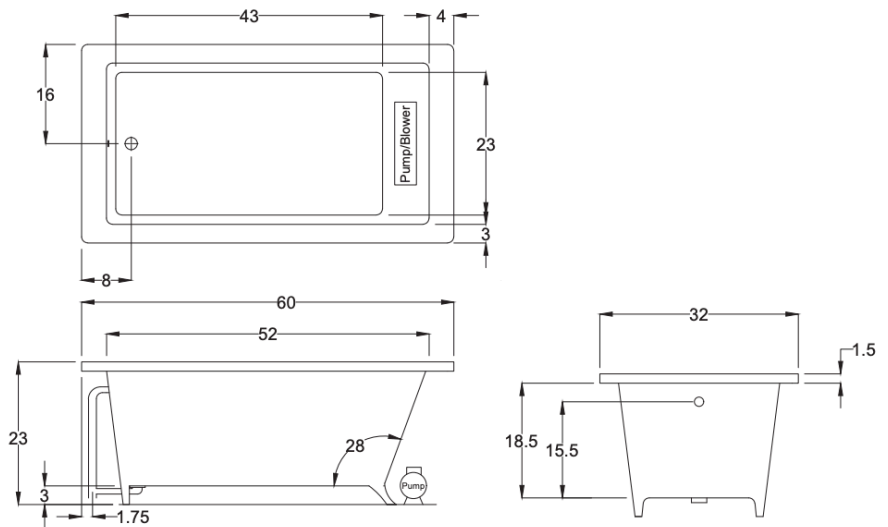

*Tub must be set in mortar base.

CODES AND COMPLIANCES

Massachusetts code File no: P1-0614-491



All specifications and options subject to change without notice please contact a Renaissance Tile & Bath representative for more information.

Beset



OR-TUB-BESETUM6632-X

SIZE:

66" x 32" x 18.5"

WATER CAPACITY:

70 Gallons

WEIGHT:

225-265 Pounds

BACK SLOPE:

28°

MATERIAL:

1-2" Nominal Thickness
solid surface material

FINISH:

Matte, Gloss

WARRANTY:

10 Year Warranty.

FEATURES:

- MicroMount available in Drop-In models.
- Integral waste and overflow included.
- Pre-wired pump on pump platform.
- Integral EZ level platform
- Overflow and drain comes standard in chrome, unless specified otherwise.
- Bathtub available in 16 different color choices

OPTIONAL:

- Thermal Air System
- Whirlpool Pump: 12"(H) x 16"(L)
- Thermal Air Blower Pump: 5"(H) x 11"(L)
- Hydro Fusion: 7"(H) x 15.5"(L)
- Hydro Indulge: 11"(H) x 19"(L)
- Electrical Requirements 1 15 AMP dedicated circuit, GFCI-115 Volts

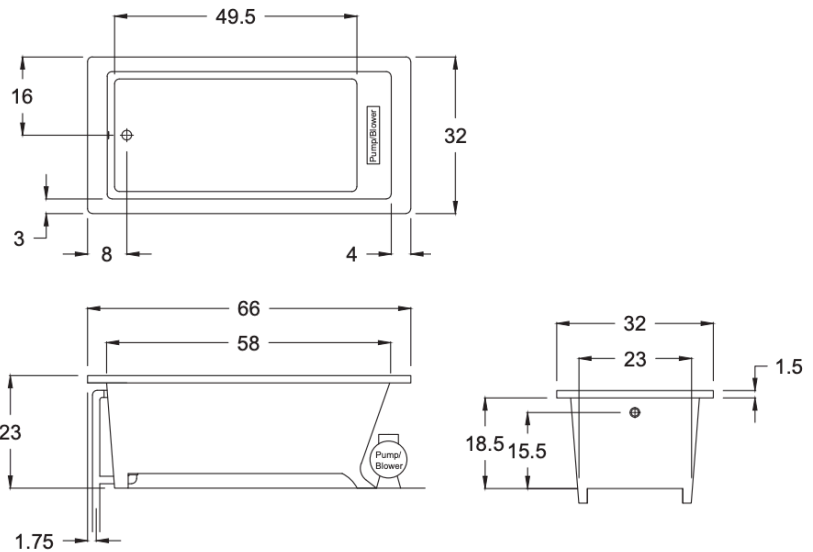

*Tub must be set in mortar base.

CODES AND COMPLIANCES

Massachusetts code File no: P1-0614-491



All specifications and options subject to change without notice please contact a Renaissance Tile & Bath representative for more information.